

Building Biology Electrical Installation

Notes for the electrical contractor!

Page 1 of 4

■ Shielded (building-safe) electrical installation:

To minimise the emission of low-frequency alternating electric fields, shielded installation cables and shielded equipment boxes are used.

- For the shielding of the components to be effective, they must be included in the potential bonding. A distinction is made between protective and functional potential bonding.

■ Definition of protective equipotential bonding:



(PE, green-yellow) serves protective purposes and is intended to prevent dangerous touch voltages as well as to ensure the rapid tripping of protective devices (e.g. circuit breaker / fuse).

■ Definition of functional potential bonding:



(FPA) is used to minimise low-frequency alternating electric fields in shielded installations. In this case, the connection wires of the coated accessory boxes are routed to the FPA rail with the shielding wires (SB) of the shielded installation cables (no further connection to a protective earth conductor). PE and FPA are only connected to the main earthing bar.

To avoid confusion with the protective conductor (PE), the shielding wire (SB) must be insulated or marked magenta (pink/pink) according to DIN EN 60445 (VDE 0197).

■ Conditions:

- Solid foundation earth electrode underneath the moisture insulation
- Application of the TN-S or TT system
- Placing shielded installation cables in a star configuration as far as possible
- Use of plaster and cavity wall device boxes in shielded design
- Residual current device with a rated differential current $I_N \leq 30$ mA.
- Include all shielded end circuits for sockets, lamps and shielded distribution and main circuits.

■ Distributor:

Step 1: Distribution box

Use protection class I distribution box (metal housing and metal door) to dissipate the alternating electric fields.

If no distribution box or sub-distribution box with metal housing is available, mount a metal plate (20 cm larger all around than the distribution box) under the box. In the case of plastered-in distribution boxes, work a fine metallic mesh into the wall cut-out. Connect the metal plate or the metal mesh properly to PE with ≥ 4 mm² cross-section. Plastic doors do not allow shielding.

Step 2: Separate busbar

for protective potential bonding PE (green-yellow) and functional potential bonding FPA (shielding wire).

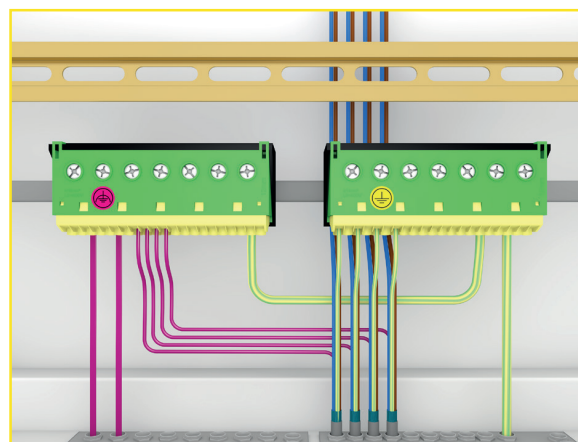

Mark functional potential bonding for clarification. Connect main earthing bar to PE as usual, connect busbar FPA and busbar PE with ≥ 4 mm² cross-section.

Step 3: Wire shielded installation cables

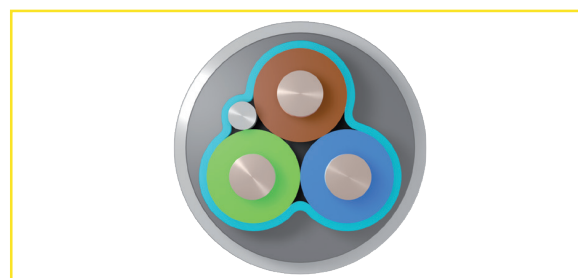

In shielded installation cables, an aluminium foil is wrapped around the cores to shield the alternating electrical fields.

A bare shielding wire (SB) is incorporated for contacting the foil.

Remove the aluminium foil when stripping the cable.

Connect the shielding wires and the green-yellow wires (PE) separately to the respective busbars, otherwise wire the wires as usual.

Safety!

All work on electrical devices and electrical systems must be carried out by a qualified electrician or under their direction and supervision!

Attention: For all work on the electrical installation, always disconnect the mains safely first and also check it!



Building Biology Electrical Installation

Notes for the electrical contractor!

Step 4: Labelling FPA

The labelling field „Functional potential bonding“ should be attached to the circuit distributor. It contains notes on the shielded electrical installation as well as the respective specialists.

Available to cut off in the FPA flyer and to print and cut out following these notes (size DIN A6).

Shielded cables and/or electrically conductive cables and/or electrically conductive wall surfaces are connected.

The shielding wires of the cables as well as the connection of the wall surfaces are connected to the protective conductor rail. If this connection is loosened, the function of the shielding is cancelled.

To increase personal and property protection, all shielded lines and wall surfaces are routed via a residual current circuit breaker with a rated differential current ≤ 30 mA.

Applicable standards:
 DIN VDE 0100-100
 DIN VDE 0100-410
 DIN VDE 0100-540
 DIN VDE 0185-305-3
 DIN EN 60445 (VDE 0197)

www.funktionspotentialausgleich.de

Your electrician:

Your consulting expert / measurement technician:

Device sockets:

The device boxes (plaster or cavity wall design) are vapour-plated with a conductive metal vacuum coating to shield the alternating electric field and are provided with a connecting wire (transparently insulated).

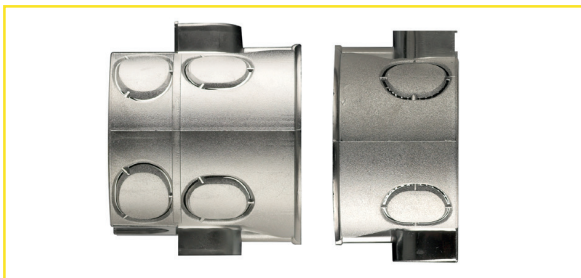

Step 5: Insulating tube magenta (pink)

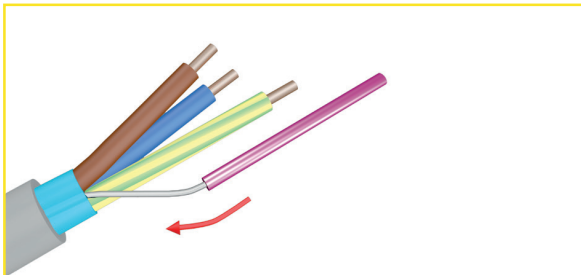

Insulating hose according to EN DIN 60445 (VDE 0197) available from Biologa Danell: ISO-F-FPA - Art.No.: 41-9062 - 760201- magenta - Ø 3,5 mm - Length: 10 Meter

Step 6: Connect box terminals

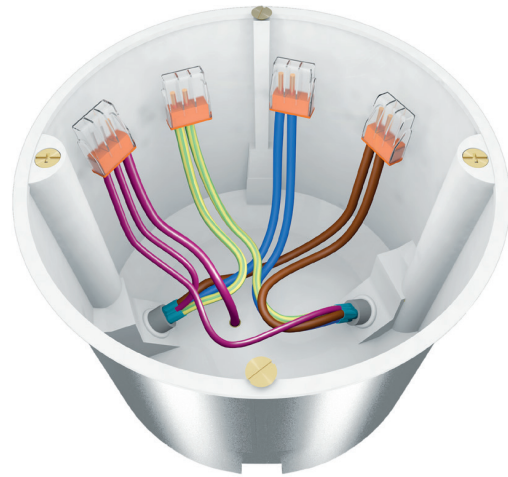

Shielded appliance outlets have a connecting wire magenta (pink) insulated, with connection to the metallic outer coating.

This connecting wire is connected to the FPA in the distribution box.

To do this, insert the magenta (pink) insulated wire and the magenta (pink) insulated connection of the device socket into the socket terminal.

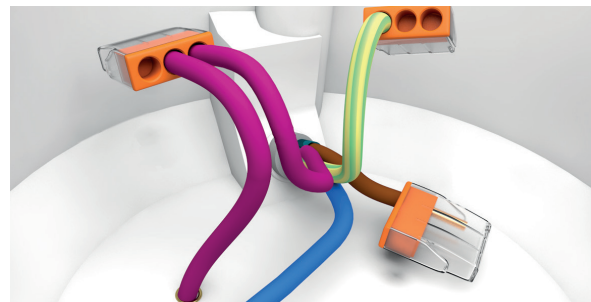

Do not use unshielded cables with shielded wall outlets!

Safety!

All work on electrical devices and electrical systems must be carried out by a qualified person and checked by a qualified electrician or under their direction and supervision!

Attention: For all work on the electrical installation, always disconnect the mains safely first and also check it!



Building Biology Electrical Installation

Notes for the electrical contractor!

Step 7: Cavity wall installation

Installation as in step 5 to 6

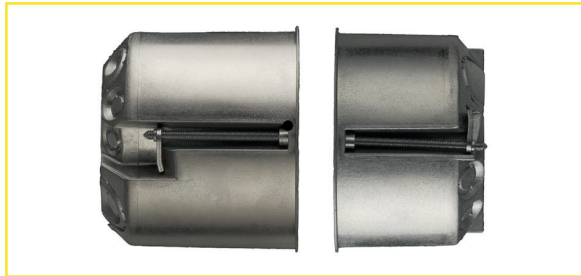

■ Specifics:

Attention: please note diffusion barrier in the outer walls of wooden houses!

If no pre-wall installation level is available, there is the option of a windproof insert (among others). Please ask the timber house supplier! Otherwise, moist interior air may penetrate the insulation layer and condensation may occur.

When opening the side tunnel exit of the cavity wall cans, apply knife or chisel from the inside and cut out, do not press.

Caution when working below living room temperature, material becomes brittle.

Typically used products for building biological (shielded) electrical installation

- Insulating tube magenta (pink)
Biologa Danell: ISO-S-FPA
- Box connecting terminals
- Labelling field „Functional potential bonding (FPA)“.
Biologa Danell - FPA flyer or printout last page
- Installation cable halogen-free (N)HXMH(St)-J
Biologa Danell:
3 x 1.5 mm², 5 x 1.5 mm², 3 x 2.5 mm², 5 x 2.5 mm²
- Appliance boxes with conductive coating and connection for FPA
- Plaster junction switch box (deep), Plaster junction switch box (flat), Cavity wall junction switch box (deep) Biologa Danell: UPSD, UPASD
- Cavity wall switch box (flat), junction box (including cover).
Biologa Danell: HWSD, HWASD, HWAK

Safety!

All work on electrical devices and electrical systems must be carried out by a qualified electrician or under their direction and supervision!



Attention: For all work on the electrical installation, always disconnect the mains safely first and also check it!

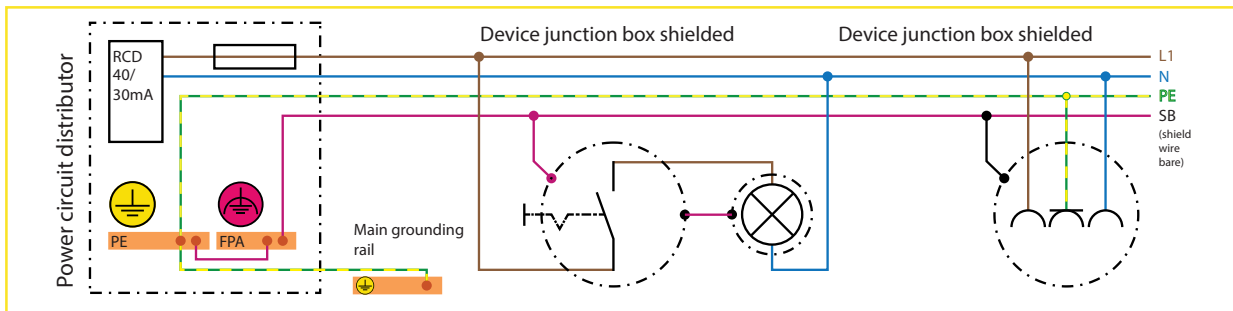

Wiring diagram Functional potential bonding - Shielded electrical installation.

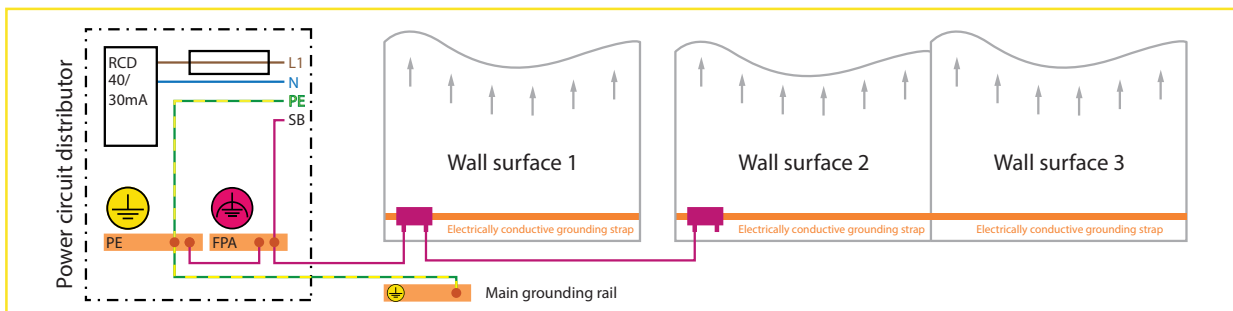

Connection diagram functional potential bonding - shielding surfaces.



Building Biology Electrical Installation

Labelling field distributor - functional potential bonding FPA

Fill in the necessary data in the labelling field (DIN A6) and then cut it out to stick it in the distribution door or attach it visibly to the documents. You can also enclose the entire FPA flyer with the distributor documents. This is supplied with device boxes and installation cables. See also www.funktionspotentialausgleich.de

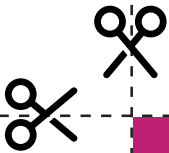

Shielded cables and/or electrically conductive cables and/or electrically conductive wall surfaces are connected.

The shielding wires of the cables as well as the connection of the wall surfaces are connected to the protective conductor rail. If this connection is loosened, the function of the shielding is cancelled.

To increase personal and property protection, all shielded lines and wall surfaces are routed via a residual current circuit breaker with a rated differential current ≤ 30 mA.

Applicable standards:

- DIN VDE 0100-100
- DIN VDE 0100-410
- DIN VDE 0100-540
- DIN VDE 0185-305-3
- DIN EN 60445 (VDE 0197)



www.funktionspotentialausgleich.de

Your electrician:

Your consulting expert / measurement technician:

